

NIR-BORESCOPE-640

THERMAL IMAGING SOLUTIONS

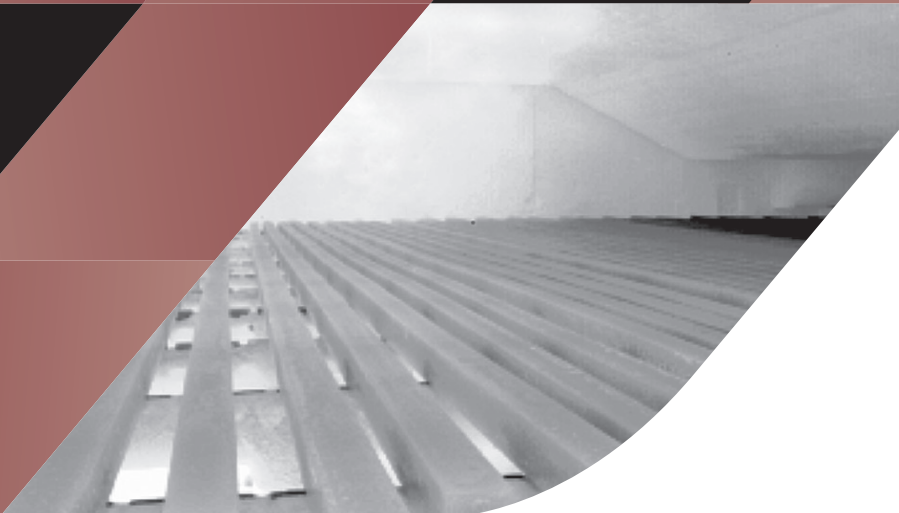

① 600 to 2000 °C / 1112 to 3632 °F



LAND
AMETEK[®]
PROCESS & ANALYTICAL INSTRUMENTS



QUALITY CUSTOMER SOLUTIONS

NIR-BORESCOPE-640

THEMAL IMAGING SOLUTIONS

AMETEK LAND HAS BEEN MANUFACTURING PRECISION MEASURING EQUIPMENT SINCE 1947.

We are specialists in non-contact temperature measurement and combustion monitoring with our products finding applications across diverse industries such as steel and glass making, power generation, cement manufacture and hydrocarbon processing.

As part of AMETEK Process & Analytical Instruments Division since 2006, our customers benefit from the worldwide AMETEK sales and service team.

The NIR-Borescope-640 (NIR-B-640) is a short wavelength radiometric infrared borescope imaging camera for continuous temperature measurement in furnace applications with a higher differential temperature in the field of view.

The NIR-B-640 provides a high-resolution thermal image with real-time continuous high accuracy temperature measurements. The camera measures temperatures in the single range of 600 to 2000 °C (1112 to 3632 °F) and utilises the latest wide dynamic range imaging technology, providing highest temperature reading accuracy over the whole wide temperature range.

Building on more than twenty years of thermal imaging experience, AMETEK Land has continued to widen its range of temperature measurement solutions by launching the NIR-Borescope-640. With the NIR-B-640 it is possible to use the proven technology of the thermal imager to accurately and continuously profile the temperature of the furnace and the stock, improving data accuracy through automation and at the same time reducing the risk to personnel by removing the need for an operator to be in the area on a regular basis. The NIR-B-640 uses an advanced

near infrared spectral filtering to provide a clear view through the furnace gases, allowing highly accurate temperature measurement point data to be taken, stored and trended over the lifetime of the furnace. The image and data processing software supports long term data trending, allowing process optimisation to be achieved.

The high-resolution image, combined with the wide-angle field of view (44° or 90°), allows multiple areas in the lane to be imaged and measured simultaneously. With advanced digital communications, the image and data can be viewed real-time in the control room in the safe area. The imager also allows the user to monitor and optimise, via the IMAGEPro thermal imaging software, the performance of the furnace; easily identifying hot and cold areas and any uneven heating can be visualised with corrections viewed in real-time. During start-up and operation phases, any burners that are not operating correctly can be clearly identified, and the effect of any impinging flames can be seen.

The NIR-B-640 is an invaluable tool in prolonging furnace lifetime, optimising production throughput, reducing energy consumption and improving stock temperatures.

FIELD OF VIEW OPTICS

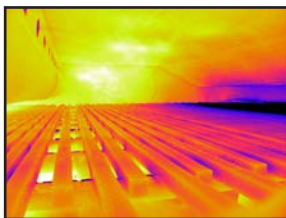

Walking beam furnace

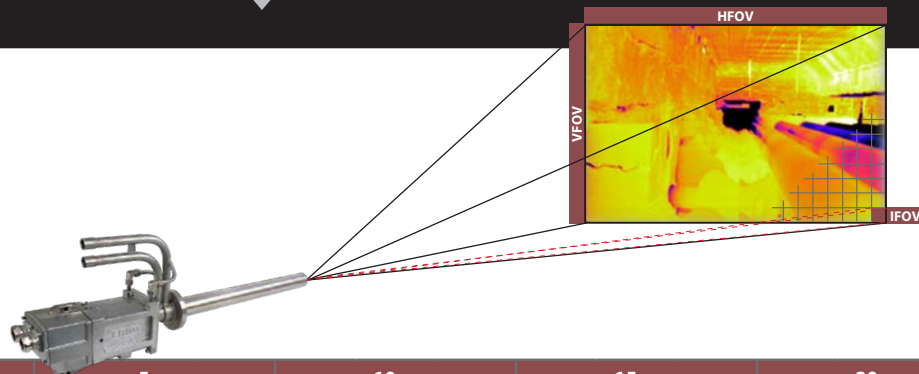

| Distance | 1 m | | | 5 m | | | 10 m | | | 15 m | | | 20 m | | |
|--------------------|-------|--------|--------|--------|--------|---------|--------|--------|---------|--------|--------|---------|--------|--------|---------|
| | Width | Height | IFOV | Width | Height | IFOV | Width | Height | IFOV | Width | Height | IFOV | Width | Height | IFOV |
| 90° x 67.5° | 2.0 m | 1.3 m | 3.1 mm | 10.0 m | 6.6 m | 15.6 mm | 20.0 m | 13.3 m | 31.3 mm | 30.0 m | 20.0 m | 46.9 mm | 40.0 m | 26.7 m | 62.5 mm |
| 44° x 33° | 0.8 m | 0.5 m | 1.3 mm | 4.0 m | 2.9 m | 6.3 mm | 8.0 m | 5.9 m | 12.5 mm | 12.1 m | 8.8 m | 18.9 mm | 16.1 m | 11.8 m | 25.2 mm |

SPECIFICATION & DESIGN

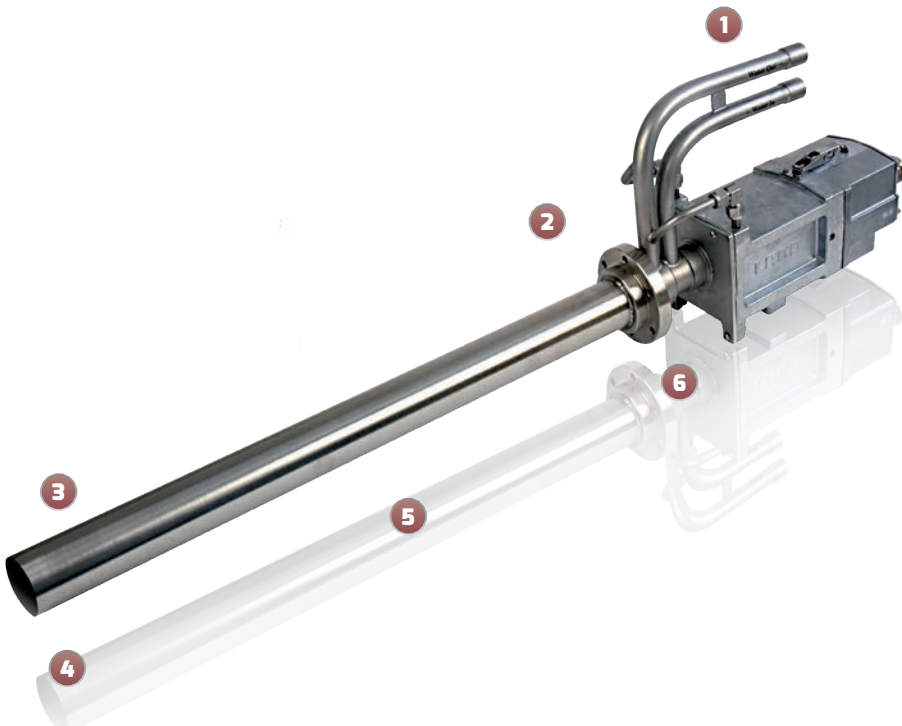

1: HIGH PERFORMANCE WATER COOLING SYSTEM

The low water flow requirements for camera unit cooling, even in the highest temperature furnaces, equal low running costs

2: RANGE OF MOUNTING OPTIONS

The most common mounting options available to ensure simple installation

3: THERMOCOUPLE AT NIR-B-640 TIP

Giving the operator an alarm for removing the instrument preventing damage if maximum temperatures are exceeded

4: VIEWING ANGLE

90° / 44° angles provide thermal views of multiple areas. 640 x 480 resolution gives 307,200 data points

5: PROBE LENGTHS

Range of probe lengths create the best fit for furnace installations

6: INTEGRATED AIR PURGE

A air purge design maintains a clean lens in harsh process environments while consuming minimal instrument air

AUTO RETRACT SYSTEMS

Designed to auto-retract and protect the thermal imager from damage by overheating in the event of loss of water flow, air pressure, electricity supply or high borescope tip temperature alarm.



TYPICAL APPLICATIONS

Cement Kiln

Cement Cyclone Furnace

Reheat Furnace

Continuous Casting (zone 1)

Heat Treatment Furnace

Annealing Furnace

FEATURES & BENEFITS

WIDE MEASURING RANGE - "cold" and "hot" areas can be measured accurately in one frame/image, so the whole process can be monitored without switching to different temperature ranges

HIGH TEMPERATURE MEASUREMENT ACCURACY - enables optimum process control through enhanced thermal imaging

ADVANCED IMAGE PROCESSING SOFTWARE - IMAGEViewer and IMAGEPro utilities to control, monitor, analyse and capture data from the thermal imaging camera

SHORT WAVELENGTH SENSOR - low sensitivity to emissivity changes

REAL-TIME THERMAL DATA COMBINED WITH HIGH RESOLUTION, LOW NOISE VISUAL IMAGE - allows true real-time furnace optimisation and the opportunity to improve energy efficiency without degrading furnace lifetime

ADVANCED SPECTRAL FILTERING - view through hot furnace gases without influence to the temperature reading

24 HOUR, 7 DAY MONITORING - Shutterless operation guarantees accurate, reliable data with no blind time

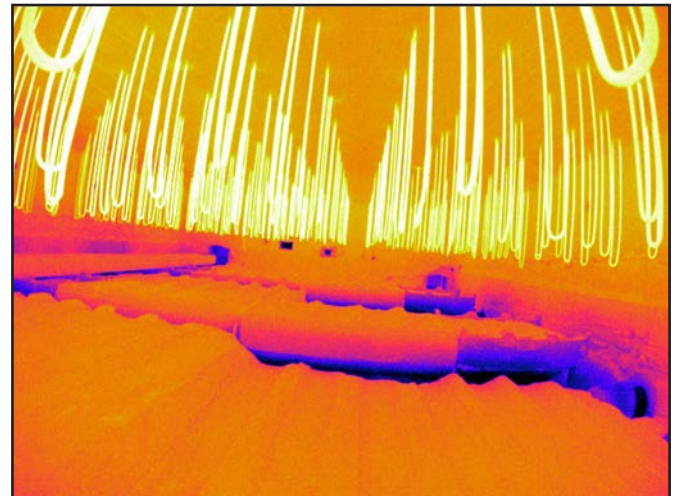

NIR-BORESCOPE-640

THERMAL IMAGING SOLUTIONS

SPECIFICATIONS

CAMERA UNIT

| | |
|-----------------------|--|
| Measurement Range: | 600 - 2000 °C / 1112 - 3632 °F |
| Pixel Resolution: | 640 x 480 |
| Spectral Response: | 1 µm |
| Frame Rate: | 7.5 fps (full frame mode) |
| Detector: | FPA - Semiconductor |
| Optic (HFOV x VFOV): | 44° x 33° / 90° x 67.5° |
| Optic (IFOV): | 1.2 mrad (44°) / 2.4 mrad (90°) |
| Focus Range: | 1 m to infinity |
| Probe Diameter: | Ø 61mm / Ø 2.4" |
| Probe Lengths: | 305, 609 or 914 mm (12, 24 or 36 in) |
| Mountings: | Choice of 3" ANSI 150 RF Flange & Gasket or PN16 DN80 Flange & Gasket with a 12" standpipe |
| Protection Window: | Sapphire |
| Accuracy: | 1% of reading (K) |
| Repeatability: | 1 K |
| Dimensions: | 254 x 560 x 717 mm (or 1021 or 1326 mm) 10 x 22 x 32 in (or 44 or 56 in) |
| Power Rating: | 21.6 - 26.4 V dc, 0.6 A |
| Weight: | < 25 kg (for 609 mm / 24 in version) |
| Environmental Rating: | IP65 / NEMA 4 |

CAMERA SUPPLY

| | |
|--------------|--|
| Connections: | Digital data over 100 M Ethernet (M12, 8 pin) |
| Service: | Water, instrument air, power input, located to the rear of the enclosure |

POWER SUPPLY UNIT (PSU)

| | |
|--------------|--|
| Components: | Power supply, Ethernet communications (switch), Fibre optic data connection (option) |
| IP Rating: | IP65 / NEMA 4 |
| Size: | 380 x 380 x 211 mm / 15 x 15 x 8.3 in |
| Weight: | 15 kg / 33.07 lbs |
| UL Approval: | Listed to UL508A & CSA-C22.2 No. File Number E499440 |

IMAGE PROCESSING

| | |
|--------------|---|
| Software: | IMAGEViewer & IMAGEPro Advanced Image Processing and Controlling Software |
| Workstation: | PC-Workstation (option) |
| Interfacing: | Open Data Interface, Modbus TCP, Moxa I/O unit |

ACCESSORIES

| | |
|-----------------------|---|
| Standard Accessories: | Power supply, cables, water-cooled/purged mounting and tube, software, workstation, auto-retraction systems |
|-----------------------|---|

AMECARE[®]
PERFORMANCE SERVICES

AMETEK Land's AMECare Performance Services ensure peak performance and maximum return on investment over the life of your equipment.

We will deliver this by:

- Proactively maintaining your equipment to maximize availability.
- Optimizing solutions to meet your unique applications.
- Enhancing user skills by providing access to product and application experts.

AMETEK Land's global service network provides unparalleled after-sales services to ensure you get the best performance and value from your AMETEK Land products. Our dedicated service centre teams and on-site engineers are trained to deliver the highest standard of commissioning, maintenance and after-sales support.



NIR-BORESCOPE-656 & NIR-BORESCOPE-2K

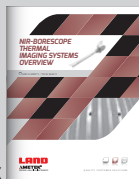

NIR-BORESCOPE THERMAL IMAGING SYSTEMS OVERVIEW



NIR-B-640-EX FORMERLY NIR-B-3XR

DISCOVER HOW OUR BROAD RANGE OF NON-CONTACT TEMPERATURE MEASUREMENT AND COMBUSTION & EMISSIONS PRODUCTS OFFER A SOLUTION FOR YOUR PROCESS

WWW.AMETEK-LAND.COM

LAND
AMETEK[®]

CONTACT US



www.ametek-land.com



land.enquiry@ametek.com



Certificate No. CC-2041
APPLIES IN INDIA



APPLIES IN THE UK



APPLIES IN THE US